



COUNTYLINE[®]

TRACTOR SUPPLY CO[®]

Assembly / Operation Instructions / Parts



TSU SKU# 1013081 VENDOR# LG 05 SS

— 5 GALLON SPOT SPRAYER —

- 5 Gallon Polyethylene Tank
- 1.0 GPM Diaphragm Demand Pump
- Lever Handgun
- Rechargeable 12V Battery
- AC Charger w/built in Storage Compartment
- Telescoping Handle
- Large 8 Inch Wheels
- 9 foot coil hose

— ASSEMBLY

This unit comes fully assembled

— GENERAL INFORMATION

The purpose of this manual is to assist you in assembling, operating and maintaining your sprayer. Please read it carefully as it furnishes information which will help you achieve years of dependable trouble-free operation.

— WARRANTY / PARTS / SERVICE

Products are warranted for one year from date of purchase against manufacturer or workmanship defects.

Your authorized dealer is the best source of replacement parts and service. To obtain prompt, efficient service, always remember to give the following information:

1. Correct part description and part number.
2. Model number of your sprayer.

Part description and part numbers can be obtained from the illustrated parts list section of this manual.

Whenever you need parts or repair service, contact your distributor / dealer first. For warranty work always take your original sales slip, or other evidence of purchase date, to your distributor / dealer.

— BATTERY CHARGING

It is recommended to charge the battery for 8-10 hours before using, or if the battery has been stored for 6 or more months without usage. Once fully charged you should be able to spray 40 gallons of fluid, or 8 consecutive tanks.

To charge the battery...

1. Plug the charger into a 110 Volt AC electrical receptacle.
2. Insert the plug on the opposite end of the charger into the charging jack located on the back panel of the sprayer.
3. Reverse the above steps when charging is complete.

CAUTION: Never leave the charger connected to the battery for more the 20 hours, as this may damage the battery.

— OPERATION

This sprayer is designed to be pulled or pushed by hand.

Pour solution into the tank and stir to mix. For liquid chemicals it is possible to mix by spraying the handgun into the tank.

Turn the switch to the "ON" position and spray by squeezing the lever on the handgun. The unit is supplied with a demand pump that will only operate while the lever on the handgun is depressed.

— TROUBLE SHOOTING

Pump will not run:

1. Check inline fuse on the wiring harness. If blown or damaged replace with a new 5 Amp fuse.
2. Insure the battery is fully charged
3. Check that the on/off switch is in the on position
4. Insure that strainer located on bottom of tank is free of debris.

— AFTER SPRAYING

After use fill the sprayer part way with water. Start the sprayer and allow clear water to be pumped through the plumbing system and out through the spray wand. Refill the tank about half full with plain water and use a chemical neutralizer such as Nutra-Sol® or equivalent and repeat cleaning instructions. Flush the entire sprayer with the neutralizing agent. Follow the chemical manufacturer's disposal instructions of all wash or rinsing water.

— WINTER STORAGE

Drain all water and chemical out of sprayer, paying special attention to pump and valves. These items are especially prone to damage from chemicals and freezing weather. The sprayer should be winterized before storage by pumping a solution of RV antifreeze through the entire plumbing. Proper care and maintenance will prolong the life of the sprayer.

— PUMP, HOSE & BATTERY ASSEMBLY

Parts List			
ITEM	QTY	PART NUMBER	DESCRIPTION
1	1	610007	1 GPM quick disconnect pump
2	1	610008	12V 5AH/20HR battery size 6FM5
3	2	610024	EL 14 QD P Quick Disconnect Fitting
4	1	610006	Retractable Handle Assembly
5	1	610025	Suction Hose Assembly
6	1	610023	W 40650 S Strainer Washer
7	4	610022	Pinch Clamp
8	2	600199	#8 x 3/4" PH TEK Screw
9	1	610002	Back Panel
10	1	610012	Economy Wand Assembly
11	1	610010	Wiring Harness
12	1	610009	12V DC 500 mA Battery Charger

①① Wiring Harness (Not Shown)

①② Battery Charger (Not Shown)

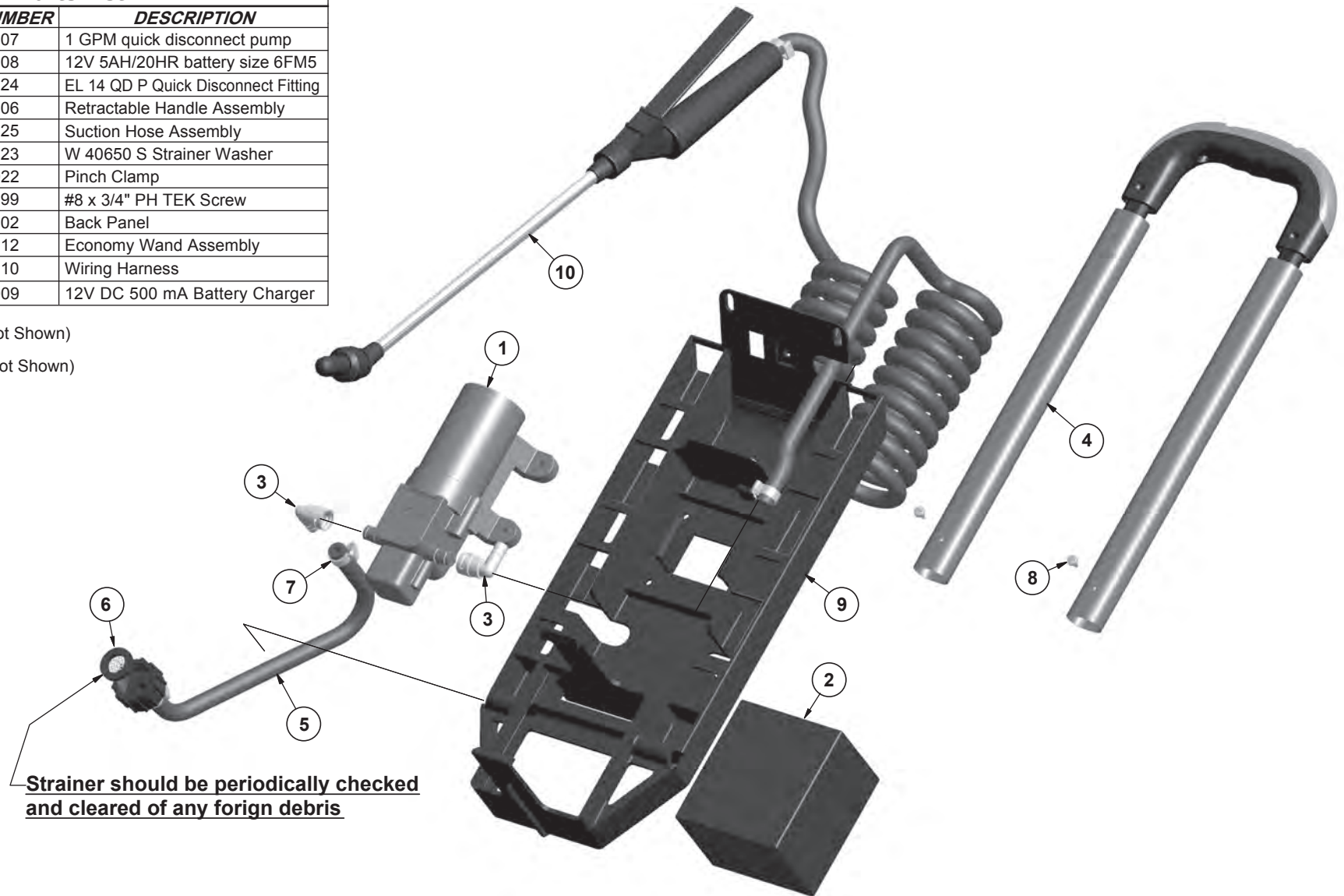

— REAR COMPARTMENT ASSEMBLY

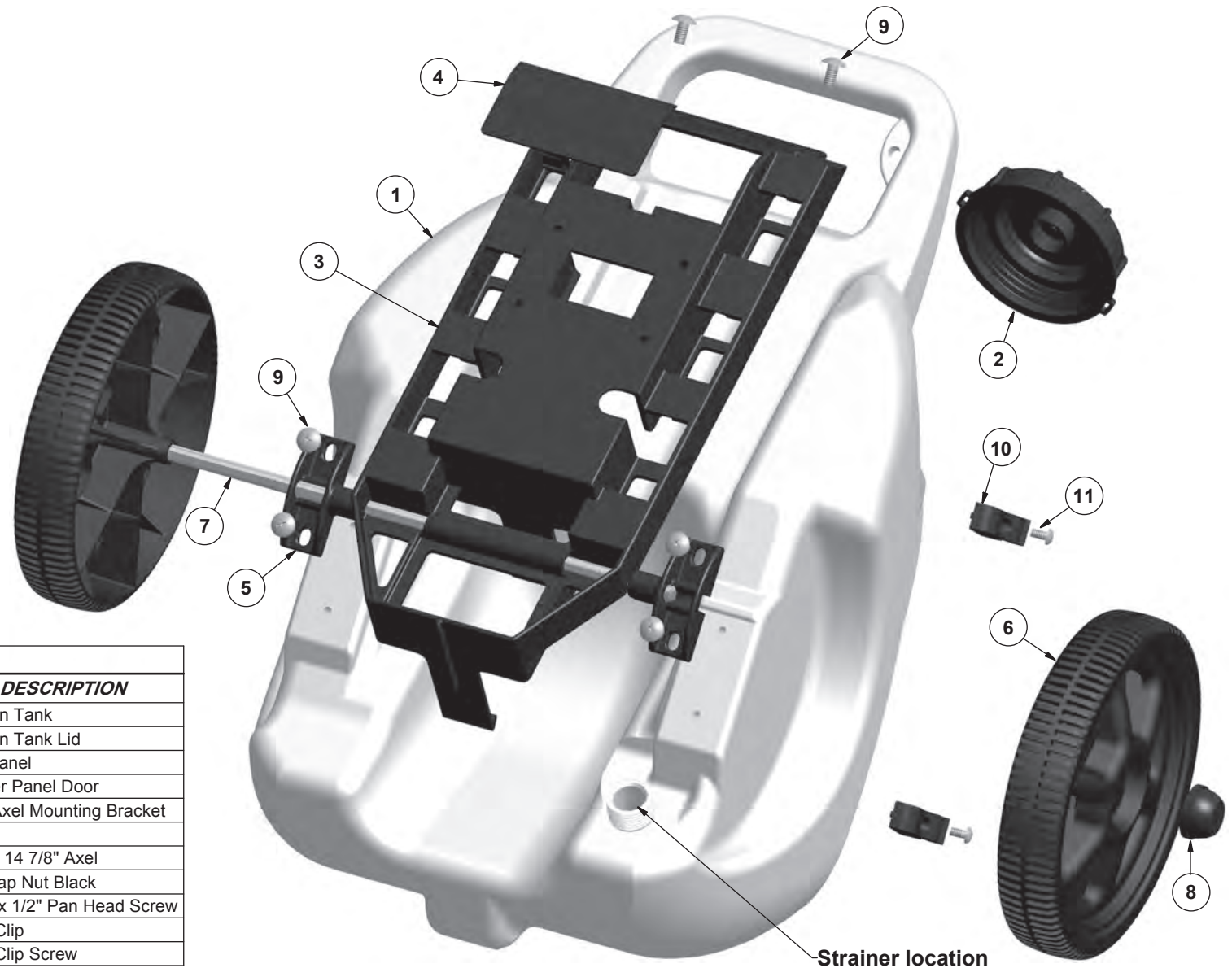

Parts List

ITEM	QTY	PART NUMBER	DESCRIPTION
1	1	610000	5 Gallon Tank
2	1	610001	5 Gallon Tank Lid
3	1	610002	Back Panel
4	1	610003	Charger Panel Door
5	2	610005	φ3/8" Axel Mounting Bracket
6	2	610004	Wheel
7	1	610013	φ3/8" x 14 7/8" Axel
8	2	610019	φ3/8 Cap Nut Black
9	6	610017	1/4-20 x 1/2" Pan Head Screw
10	2	600151	Wand Clip
11	2	600152	Wand Clip Screw

PowerFLO™ 2200 Series



Specifications

Motor

Type: 12 VDC, permanent magnet, thermally protected, splashproof

Leads: 2200-2 Model: 18 AWG, 4.5" long w 2-pin connector

Duty Cycle: Intermittent

Pump

Type: 2-chamber positive displacement, self priming, capable of being run dry

Liquid Temperature: 110°F (43°C) Max.

Priming Capabilities: 4 feet (1.2 m) suction lift

Max Pressure: 40 PSI (2.8 bar)

Pressure Demand Switch:

Shut-Off: 40 ±5 PSI (2.8 ±0.3 bar) factory setting

Turn-On: 25 ±5 PSI (1.7 ±0.3 bar) factory setting

Inlet/Outlet Ports: Quick Disconnect

Weight

1.25 lbs (0.57 kg)

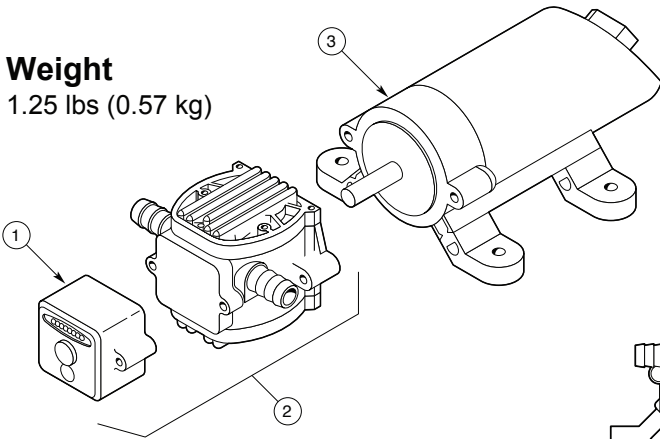

Parts List

Ref #	Description	Part Number
1	Switch Assembly	5157201
2	Pump Head w Switch Assembly	5275064
3	Motor with connector, no switch	P39-045B

Performance

Pressure/Flow/Amp Draw

PSI	Bar	GPM	LPM	Amps
0-3	0.2	1.00	3.7	1.5
10	0.7	0.85	3.1	1.9
20	1.4	0.71	2.6	2.1
30	2.1	0.61	2.3	2.4
40	2.8	0.42	1.6	2.6

Materials of Construction

Motor Housing: Nylon 6/6

Pump Housing: Polypropylene

Valves: Viton

Diaphragm: Santoprene

Fasteners: Stainless steel and zinc plated

Ordering

Model Number

Item #	Description
2200-201	1 GPM Demand Pump, Viton Valves, Santoprene Diaphragm, 40 PSI, Quick Disconnect Ports 2-pin molded connector

Dimensions Inches (mm)

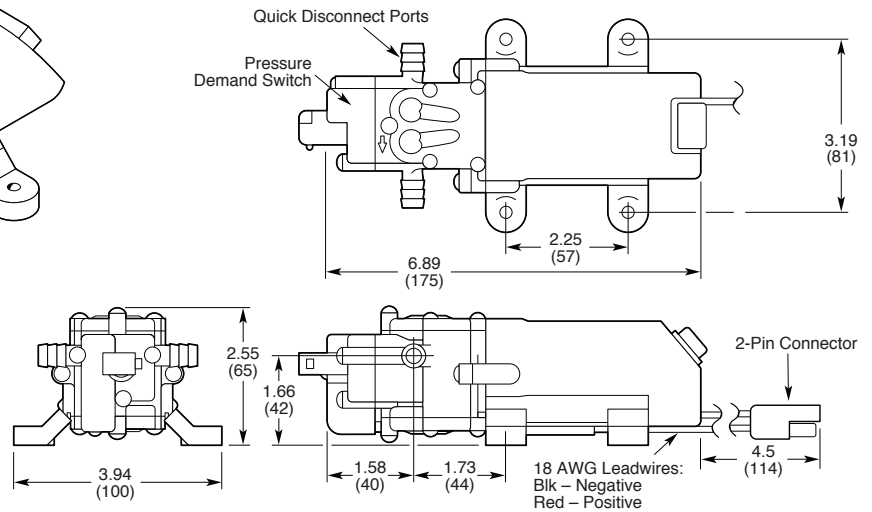

12 Volt DC Motor-Driven Diaphragm Pumps

Operation Precautions

1. **Do not operate pump in an explosive environment.**
Arcing from the motor brushes, switch or excessive heat from an improperly cycled motor may cause an explosion.
2. **Do not pump gasoline or other flammable liquids.**
3. **Do not assume fluid compatibility.** If the fluid is improperly matched to the pumps' elastomers, a leak may occur.
4. Intermittent duty is defined as operation and/or frequent starting within a period of time that would cause the motor to reach its maximum thermal limits.

Once the maximum is obtained, the motor must be allowed to return to ambient temperature before resuming operation.

Troubleshooting Guide

Problem/Causes and Remedies

Pump will not Start

Check:

- Correct voltage ($\pm 10\%$) and electrical connections
- Fuse or breaker
- Pressure switch operation and correct voltage at switch
- Rectifier or motor for open or grounded circuit
- Locked drive assembly

Pump will not Prime (No discharge with motor running)

Check:

- Debris in strainer
- Restriction (kinks) in inlet/outlet tubes
- Debris or swelling in inlet/outlet valves

Pump will not Shut Off (Output line closed and no leaks)

Check:

- Air trapped in outlet line or pump head
- Correct voltage to pump
- Debris in pump inlet/outlet valves
- Loose drive assembly or pump head screws
- Pressure switch operations/adjustments

Leaks from Pump Head or Switch

Check:

- Loose screws at switch or pump head
- Switch diaphragm ruptured or pinched
- Punctured diaphragm if fluid is present

Standard Warranty

Delavan warrants PowerFLO Series Pumps for a period of one year from date of manufacture.

All products sold by Delavan are warranted only to purchasers from Delavan for resale or for use in purchasers' own business or original equipment manufacture, against defects in workmanship or materials under normal use, maintenance and service (rental use excluded).

The sole and exclusive obligation of Delavan under this or any implied warranty shall be to replace or, at its option, to repair, without charge, any product which is determined by Delavan to be defective in workmanship or materials after the product is returned to the Delavan factory*, shipping costs prepaid.

In no event shall Delavan be liable to any person for indirect or consequential damages or for injury or commercial loss resulting from any use or inability to use any Delavan product. Delavan expressly negates any other warranty, express or implied, including any warranty of merchantability or fitness for a particular purpose, or arising from any course of dealing or custom or usage of trade.

No person, including any dealer or representative of Delavan, is authorized to make any representation or warranty on behalf of Delavan in addition to or inconsistent with these provisions. Purchasers to whom these provisions apply agree to hold Delavan harmless from claims by their customers in excess of the obligations of Delavan expressly set forth herein.

*** Important return safety instructions:**

When you return your pump for warranty or repair, you must always do the following:

1. Flush chemical residue from the pump (best done in the field).
2. Tag pump with type of chemicals having been sprayed.
3. Include complete description of operation problem, such as how pump was used, symptoms of malfunction, etc.

Since pumps can contain residues of toxic chemicals these steps are necessary to protect all the people who handle return shipments, and to help pinpoint the reason for the breakdown.